

## MACHINE STANDARD SPECIFICATIONS

Projector		Effective screen size	500 mm x 500 mm
		Magnification	x20 x50 (switching system)
		Projecting size	x20 25 mm x 25 mm
			x50 10 mm x 10 mm
Lighting system: transmission		LED	x50 10 mm x 10 mm
reflection		Halogen 100 V 500 W	
Machine size			
Width x Depth x Height	1,615 mm x 1,995 mm x 2,120 mm		
Weight	4,500 kg		
Rated capacity			
Total electrical capacity	7 kVA		
Required air pressure source pressure	0.4 MPa or more (L type)		
	0.3 MPa or more (R type)		
Required air pressure source capacity	100 L/min (ANR)		
Power supply	3-phase 200/220 V (+10%~+15%) 50/60 Hz (±1 Hz)		

## NC STANDARD SPECIFICATIONS

NC system		FANUC series 32i MODEL B
Number of control axes		XYUWZ 5 axes (L type)
Number of simultaneous control axes		XYUW 4 axes (R type)
Minimum setting unit		XY 2 axes
		X · Y 0.0001 mm
		U · W 0.0001 mm
		Z 0.0001 mm (L type)
Minimum moving unit		X · Y 0.0001 mm
		U · W 0.0002 mm
Position detection		X · Y · U · W Semi closed loop
		Z 0.1 μm Linear scale (L type)
Manual pulse generator X, Y axis		x1 0.1 μm/notch
		x10 1 μm/notch
		x100 10 μm/notch
U, W axis		Foot pedal OFF 0.2 μm/notch
		Foot pedal ON 50 μm/notch

## NC OPTIONS

SPG Lab	15" Color LCD monitor (with PC)
Fully closed loop for X · Y axes	
Fully closed loop for U · W axes	
Semi closed loop counter for U · W axes	Counter display (with scale for fully closed loop)
English specification (mm)	Monitor, Pendant
Chinese specification (mm)	Monitor, Pendant
Fanuc operation display in English (mm)	
Fanuc operation display in Chinese (mm)	
Additional program capacity	128 Kbyte, Number of programs: 1,000
Projector transparent high bright LED	With ON/OFF switch and dimming volume
Projector transparent halogen	
Projector transparent halogen voltage adjusting switch	
Projector reflective high bright LED	With ON/OFF switch and dimming volume
Projector reflective halogen voltage adjusting switch	
No projector reflection	Removing the reflective lighting (for cylindrical users)
Playback function	Creating a program by teaching
Repeat cycle function	Executing repeatedly by shifting the pitch the XY program created with playback
Manual linear / manual circular interpolation (LTP/CITP)	Performing interpolation of XY straight lines and circular arcs by operating the handle.
Tool diameter offset	Grinding while changing the depth of cut (tool radial direction) of the playback program.
Tool length offset	Grinding while changing the depth of cut (XY) of the playback program.
Flange cut roughing cycle	Grinding method PRCR (adding the contouring function with a flat grinding wheel)
Multiple workpieces continuous grinding	Grinding multiple workpieces continuous by offsetting UW axis automatically.
Multiple workpieces continuous grinding number of registrations	100
Handle sync feeding	A function to shift the program progressively by handle operation.
Handle interrupt function	A function to intervene in the XY handle during automatic operation suspension.
Always handle interrupt function	A function to intervene in the XY handle during automatic operation or suspension.
Dressing software	
3 axes playback function	Create a playback program interpolating operation of XYZ axes.
Screw grinding	Up to 8 threads

## SPECIAL ACCESSORIES

Variable angle expansion	Front: -1~20°, Side: ±15
Dry dust collector (with Pre-box)	
Dust collector for both dry/wet	With water feeding tank (60 L)
Dust collector for both dry/wet with paper filter	With water feeding tank (100 L)
Mist collector	With table
Wet device	With hand pump for refueling to swiveling unit
Small wheel (Φ30/75) spindle: 1ZUL	With oil cooling function: 1.6 kw 4 P, Spindle speed: 3,000~30,000 min <sup>-1</sup>
Large wheel (Φ150, Φ180) spindle	With oil cooling function: 1.7 kw 4 P, Spindle speed: 3,000~10,000 min <sup>-1</sup>
Air spindle	Spindle speed 30,000 min <sup>-1</sup>
Medium diameter spindle	Spindle speed 20,000 min <sup>-1</sup>
Wheel flange Φ75	With balance piece
Wheel flange Φ90~120	With balance piece
Wheel flange Φ150	With balance piece
Wheel flange Φ180	With balance piece
Grind sound detector (SR-30)	
Workpiece fine adjusting base	
Magnet chuck for fine adjusting base with iquel	
Precision vise NP30-1	
Work swiveling table SWT-20	
Fine adjustment base for work swiveling table	
Dressing device on the machine DR310	
Compact dressing device on the machine DR100 (compact type)	For general wheel
Grinding wheel auto balancer (balance eye Z)	With scale circle
Auxiliary lighting system single light 4000	
Halogen lamp 100 W/500 W	
Special projector X25 X50	
Moving type loupe (lens X3 or lens X4)	
Loupe (X4)	
Air gun	

Wheel unit		Travel amount	X axis 200 mm
			Y axis 170 mm
Wheel outer diameter		Small diameter spindle (Φ40 mm~Φ90 mm)	
		Large diameter spindle (Φ150 mm, Φ180 mm)	
Spindle speed		Small diameter spindle 3,000~20,000 min <sup>-1</sup>	
		Large diameter spindle 1,000~10,000 min <sup>-1</sup>	
Front variable setting range		Standard -1°~+2°	
Side variable setting range		Standard ±3°	
Horizontal swiveling angle range		±15°	
Linear motor drive		Stroke 0~300 st/min	
		Stroke amount (Z axis) 0, 5~160 mm	
Reciprocating link drive		Stroke 0, 30~400 st/min	
		Stroke amount (Z axis) 0, 5~110 mm	
Work table			
Size		600 mm x 180 mm	
Travel amount		U axis 300 mm	
		W axis 150 mm	
		Up & Down 150 mm	

Self diagnosis function		When an alarm occurs, the cause can be checked on the alarm screen.
		If operation is stopped, the status can be checked on the self diagnosis screen.
Spindle torque select		Fine mode Suitable for high precision grinding
		Power mode Suitable for rough grinding
Grinding wheel speed changing function		Changing the grinding wheel rotation speed automatically in a fixed cycle.
Oscillation speed changing function		Changing the oscillation speed automatically in a fixed cycle.
Working time display		Integration time for NC operation during starting up
		Displaying the running time of NC operation at once
Oscillation JOG speed switching function		Oscillation JOG speed can be switched in 3 steps.
		JOG speed can be set by parameter
External interface (Input-Output)		Memory card, USB port
		(Inputting/Outputting G code data)
Pendant		MDI & CRT
		100 V socket
		2 pcs (total: 300 W)
		Notation for monitor & pendant
		Standard : English specification (mm)
		FANUC display
		Standard : English specification (mm)

Signal tower	WL-L24V-3RYG-E 3 lights
Additional 100 V socket capacity	Total: 500 W
Wheel Ammeter	Add analog meter and square meter (0~30 A) to the top of the operation panel
Cylindrical I/F	
Work swiveling table I/F SWT-20	
CCD measuring system	Including original software (without grinding wheel measuring software)
Table position evacuation switch	W axis moves backward and U axis moves to the front, if switching ON again, the opposite movement is executed.
External I/O interface ethernet	I/O of programs on external devices (PC), and connect to NC built-in Ethernet
External I/O interface RS232C	
Calendar timer	

## SPG Lab OPTIONS

Single playback function	
Tool position display	
User coordinates, User coordinate extension	
Shape target	Target command
Shape sub program	Sub program command
Shape move	Move command
Simple R cutting	Grinding a circle 1/4. Two types of grinding each left and right corner can be done
Radius change	Changing the radius of the arc specified arc center
Tangential arc	Changing the radius of the arc between the two straight lines
Inversion point / Moving point	Creating as a new shape program after program conversion
Origin setting	Setting the origin and tool diameter by adapting with the reference circle of the chart
Z axis offset	Start up setting: Z axis does not move and oscillate to the specified coordinates
Work table teaching	Start setting: inputting offset amount with teaching
	*Selecting available only when UW axis fully closed loop.
C axis normal grinding software	
Ta bar grinding software	
FANUC mode	Mode to operate the machine on the FANUC screen (in English)

Cylindrical grinding device: OG-162	Offset range: Φ160, Length between centers: 200 mm
Manual indexing device for OG-162	
Base T-slot for OG-162, Vertical and horizontal 2 threads specifications	
Cylindrical grinding device: OG-162 T N	Swivel range of main spindle: 90° (no tailstock)
Cylindrical grinding device: OG-162 T N T	Swivel range of main spindle: 90° (with tailstock)
Scroll chuck 4" for OG-162 (SC-4A)	With adjustment mechanism for centering
Scroll chuck 5" for OG-162 (SC-5A)	With adjustment mechanism for centering
Face plate for OG-162 5"	
Iris diaphragm (for cylindrical grinding)	
NC vertical indexing device: CT-5FA (fully closed loop)	
NC horizontal indexing device: IH-4FA (fully closed loop)	
Scroll chuck 4" for IH-4FA (SC-4A)	With adjustment mechanism for centering
Cylindrical and horizontal indexing device OG-H	
Scroll chuck 4" various for OG-H (SC-4A)	With adjustment mechanism for centering
Scroll chuck 4" various for OG-H (SC-4A)	With adjustment mechanism for centering
Scroll chuck 5" various for OG-H (SC-5A)	With adjustment mechanism for centering
Face plate for OG-H   4" and 5"	
Vertical and horizontal indexing device CT-H	
Scroll chuck 5" for CT-H	
Scroll chuck 4" for CT-H	
Face plate for CT-H   5" and 6"	
Iquel for CT-H	
WAIDA grinding wheels	
Dust proof glass for transmission	
Dust proof glass for reflection	
Chart paper	
Tool cabinet MC-282	
High precision chart marking system NSP-55	
Universal arm (with tool holder)	Attached to the manual handle for X, Y

## MACHINE LAYOUT

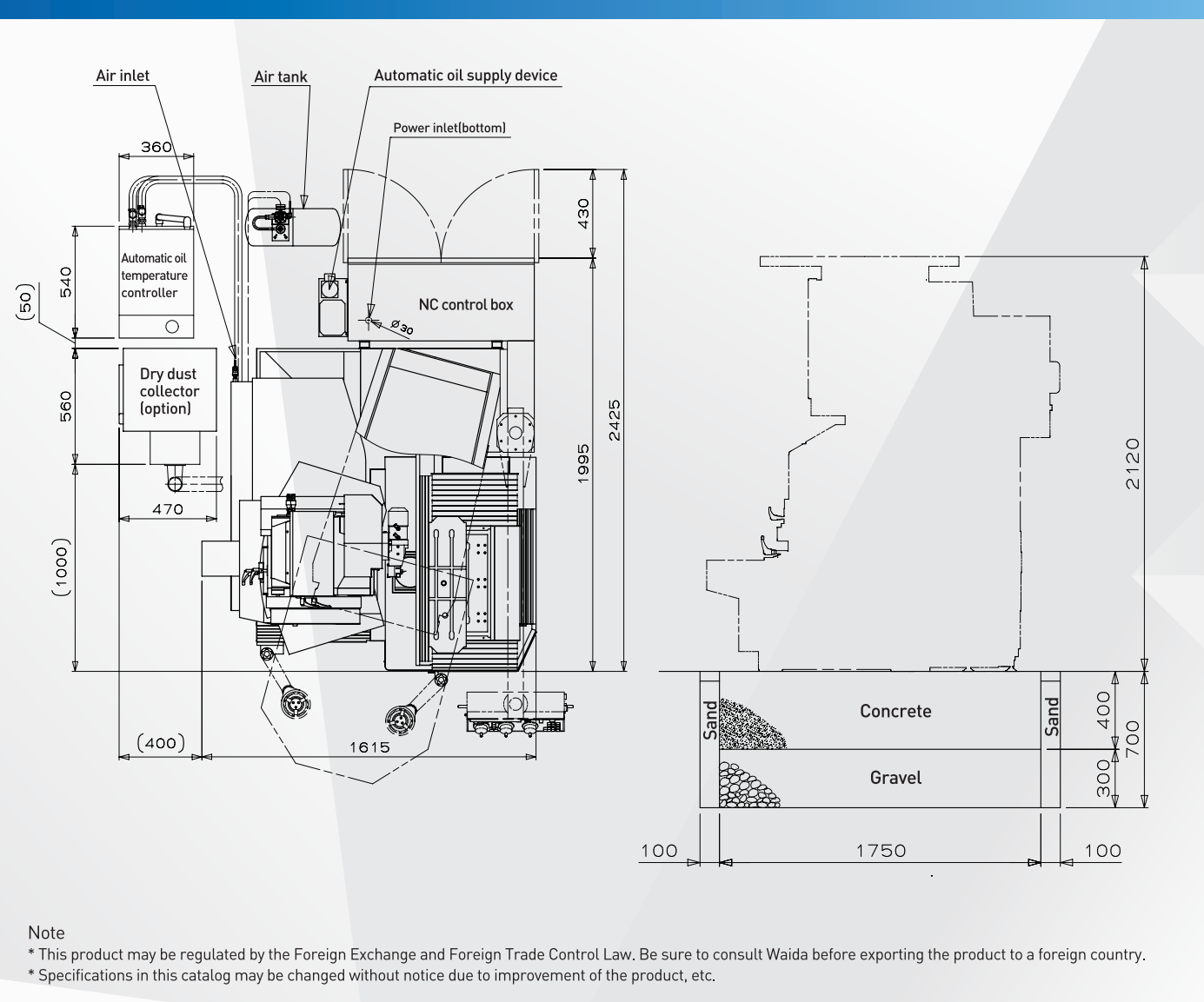

## WAIDA WAIDA MFG.CO.,LTD.

Head Office and Factory  
Gifu Factory  
Tokyo Branch Office  
Chubu Office  
Osaka Office  
Shanghai Representative Office  
Hamamatsu Factory  
U.S.A. North Carolina Office  
WAIDA FEELER PRECISION MACHINERY CO., LTD.  
WAIDA Europe GmbH

2121, Katano-machi, Takayama City, Gifu 506-0824 Japan  
191, Kinzoku Danchi, Kakamigahara City, Gifu 504-0957 Japan  
10F CIRCLES Shinbashi, 2-11-13, Nishi-Shimbashi, Minato-ku, Tokyo 105-0003 Japan  
191, Kinzoku Danchi, Kakamigahara City, Gifu, 504-0957 Japan  
7F, 11-21, Nishi Nakajima 4-Chome, Yodogawa-ku, Osaka 532-0011 Japan  
Rm 1015, Zhongchuang Bldg., 819 West Nanjing Road, Shanghai 200041 China  
300-1, Toyooka-cho, Kita-ku, Hamamatsu City, Shizuoka 433-8103 Japan  
2520 Whitehall Park Drive, Suite 350, Charlotte, NC 28273, U.S.A.  
No.558-1, Shenzhou Rd., Shengang Dist., Taichung City 42942, Taiwan(R.O.C.)  
Theodor-Heuss-Allee 112, 60486 Frankfurt am Main, Germany

TEL +81-577-32-0390  
TEL +81-58-382-3218  
TEL +81-3-6811-3251  
TEL +81-58-382-2911  
TEL +81-6-6305-6461  
TEL +86-21-6255-6035  
TEL +81-53-523-6711  
TEL +1-980-335-0621  
TEL +886-4-25285759  
FAX +81-577-37-0020  
FAX +81-58-380-0030  
FAX +81-3-6811-3253  
FAX +81-58-389-4409  
FAX +81-6-6307-2338  
FAX +86-21-6215-1389  
FAX +81-53-523-6712  
FAX +886-4-25283125



# SPG-X Profile Grinder

SPG-X meets a wide range of customer needs and easily achieves the highest surface quality. This is a new global standard model with improved operability and visibility.



## Achieving a compact machine

We have reduced more than 18% of the area required for machine installation comparing with conventional model. It is possible to save space.

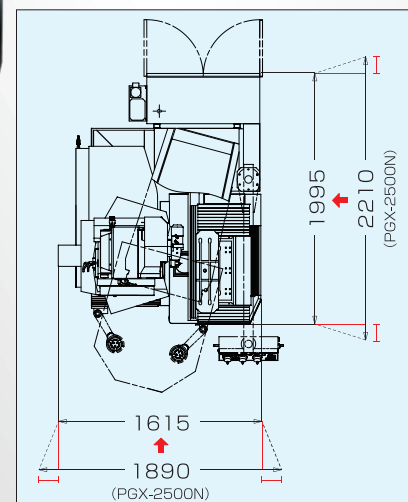

## 1 WAIDA intelligence software [SPG Lab]

Flexible response to the operation is possible in speedy by using interactive software [SPG Lab] according to the grinding wheel and condition of workpiece.

\*OPTION



## 2 Evolution of the wheel unit structure [Long stroke linear motor]

The standard-equipped linear motor for mass production type

Stroke amount (Z axis): max 160 mm

Shortening stroke adjustment time drastically.

\*Conventional reciprocating type can be selected



## 3 Evolution of the inner projector [The new standard-equipped LED transmitted illumination]

LED standard equipment for transmitted illumination. Illuminance 1.5 times that of conventional halogen lighting. Eliminating the effect of heat mutation on accuracy thoroughly.



## 4 Possible to measure with a tolerance of $\pm 1 \mu\text{m}$ [CCD Measuring system] <OPTION>

Possible to digital measurement tolerance of  $\pm 1 \mu\text{m}$  without removing the workpiece.

Possible to check fine shape and narrow radius at X500.

Accuracy control can be leveled up surely in combination with a projector.

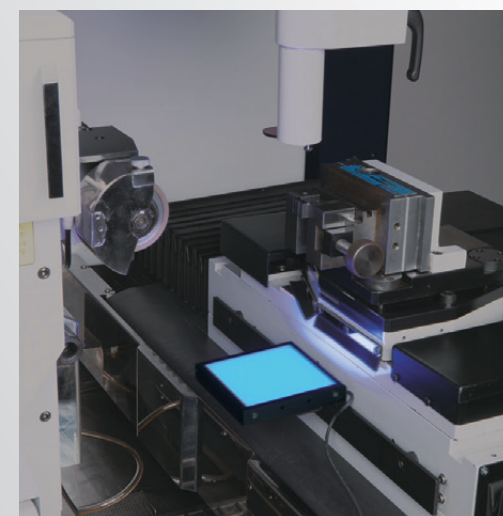
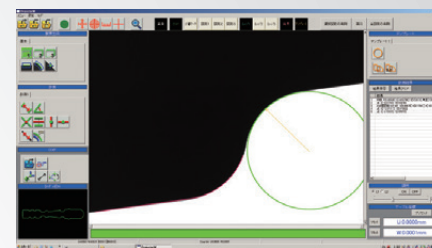

## SUPPORTING ITEMS FOR GRINDING



### Turn Table SWT-20

Turn setting angle: left and right 0°, 10°, 15°, 20°

\* Making easy to setup with dedicated fine adjusting base (option)

### Cylindrical and horizontal indexing device OG-IH

Diameter (max):  $\Phi 260$  mm (partly 180 mm)

Length between centers: max 220 mm

Min setting unit: 0.0001°

\*Scroll chuck is optional

Through hole:  $\Phi 40$

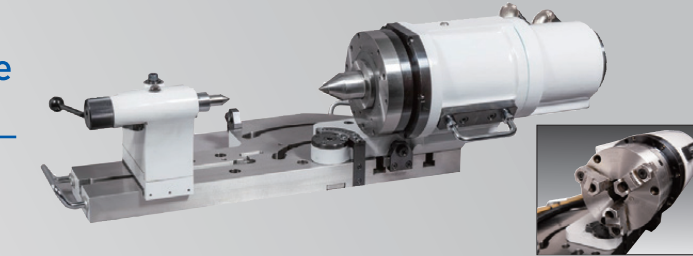
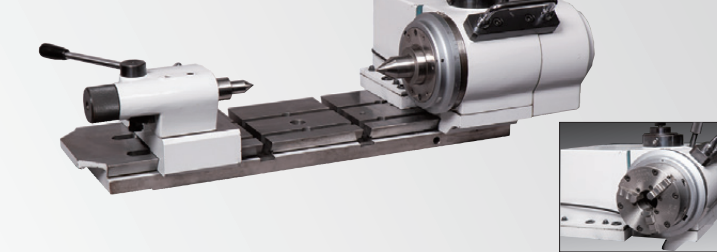

### Cylindrical Grinding Device OG-162

Speed (RPM): 60 to 1,000 min<sup>-1</sup>

Diameter (max): 160 mm

Height of Spindle center: 85 mm

Length between centers: 200 mm

\*Special correspondence is possible depending on your purpose

\*Scroll chuck is optional

### Vertical and horizontal indexing device CT-IH

Through hole spindle structure

Minimum setting unit: 0.0001°

\*Scroll chuck is optional

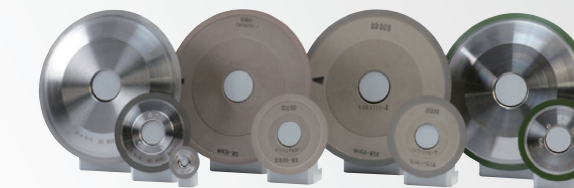
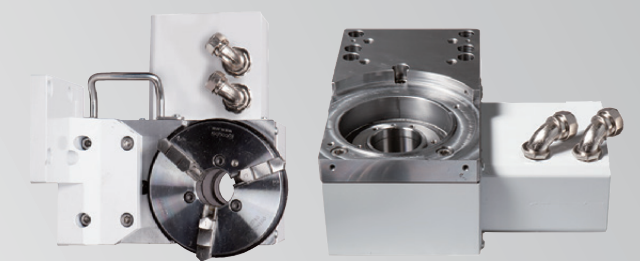

### WAIDA W Series of grinding wheels

Achieving preeminent sharpness and high surface quality, reducing the grinding time.

A wide variety of Waida original grinding wheels for various purposes. Introducing a new type for more delicateness and precision.

### On-Machine Grinding Wheel Dressing Device DR-310

Waida original grinding wheels dressing device



### High-Precision Chart Marking System NSP-55

Plotting accuracy:  $\pm 0.02$  mm or less, Simultaneous XYZ 3-axis control

Profile chart dedicated machine. Space-saving design.

Plotting area: 500 mm x 500 mm